

# MONROE THREE-SIDED CAMPFIRE INDOOR GAS FIREPLACE

## Balanced Flue System

### BALANCED FLUE SYSTEM

Monroe is a gas fireplace (NG or LPG) with a balanced flue system that utilizes closed combustion and does not affect the air in the room. The coaxial pipe both supplies the fireplace with fresh air and extracts any combustion products outside.

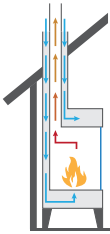

BALANCED  
FLUE SYSTEM



### ADVANCED FEATURES

The **thermostat** maintains a desired room temperature  
**Modular Ignition** reduces water vapour condensation  
**Eco Flow** regulates flame height over time

### CONVENIENT REMOTE CONTROL

Sinatra offers convenient control options: the included handheld remote, an optional Smart Home System controller or a mobile app on your smartphone.



### ENCLOSED BEHIND GLASS

Monroe is enclosed with ceramic glass. Optionally you can choose panels with antireflective coating that reduce reflections making the flame look even more vibrant.

### SAFETY FEATURES

- Lack of flame detection
- Seismic activity sensor
- Gas leak sensor
- Draft interrupter
- CO sensor
- Child lock

### TWO-SECTION CAMPFIRE BURNER

The vertical campfire burner introduces a classic fire design to your interior. It is decorated with ceramic logs, vermiculite, slate chips and glowing fiber. As an option you can choose an elegant high-gloss black ceramic glass for the back wall.



optional black ceramic glass

All product specifications and data are subject to change without notice and are believed to be accurate as of the date hereof. Planika Sp. z o.o., its affiliates, agents, and employees, and all persons acting on its or their behalf (collectively, "Planika Sp. z o.o."), disclaim any and all liability for any errors, inaccuracies or incompleteness contained in any document or in any other disclosure relating to any product. To the maximum extent permitted by applicable law, Planika Sp. z o.o. disclaims any and all liability arising out of the application or use of any product. This document does not expand or otherwise modify Planika Sp. z o.o.'s terms and conditions of purchase, including but not limited to the warranty expressed therein. No license, express or implied, by estoppel or otherwise, to any intellectual property rights is granted by this document or by any conduct of Planika Sp. z o.o.. Customers using or selling Planika Sp. z o.o.'s products not expressly indicated for use in such applications do so entirely at their own risk and agree to fully indemnify Planika Sp. z o.o. for any damages arising or resulting from such use or sale. The images are indicative only.

## Monroe Three-Sided (Balanced Flue Gas Fireplace)

Fuel type	Natural Gas or LPG
Flue and fresh air intake	Ø 200/130 mm concentric flue (coaxial pipe)
Nominal heat input	NG max. 11.0 kW LPG max. 12.2 kW
Gas consumption	NG max. 1.2 m <sup>3</sup> /h LPG max. 1.0 kg/h
Flame height regulation	15 levels
Materials	steel, ceramic glass
Power supply	230V / remote control: 2x AA batteries
Weight	135.0 kg
Application	for indoor use only

### CONTROL OPTIONS

Ways to control the fireplace remotely.



included



WiFi

optional



SHS

compatible

### 'PLANIKA CONTROL' APP

Control the fire with your smartphone.

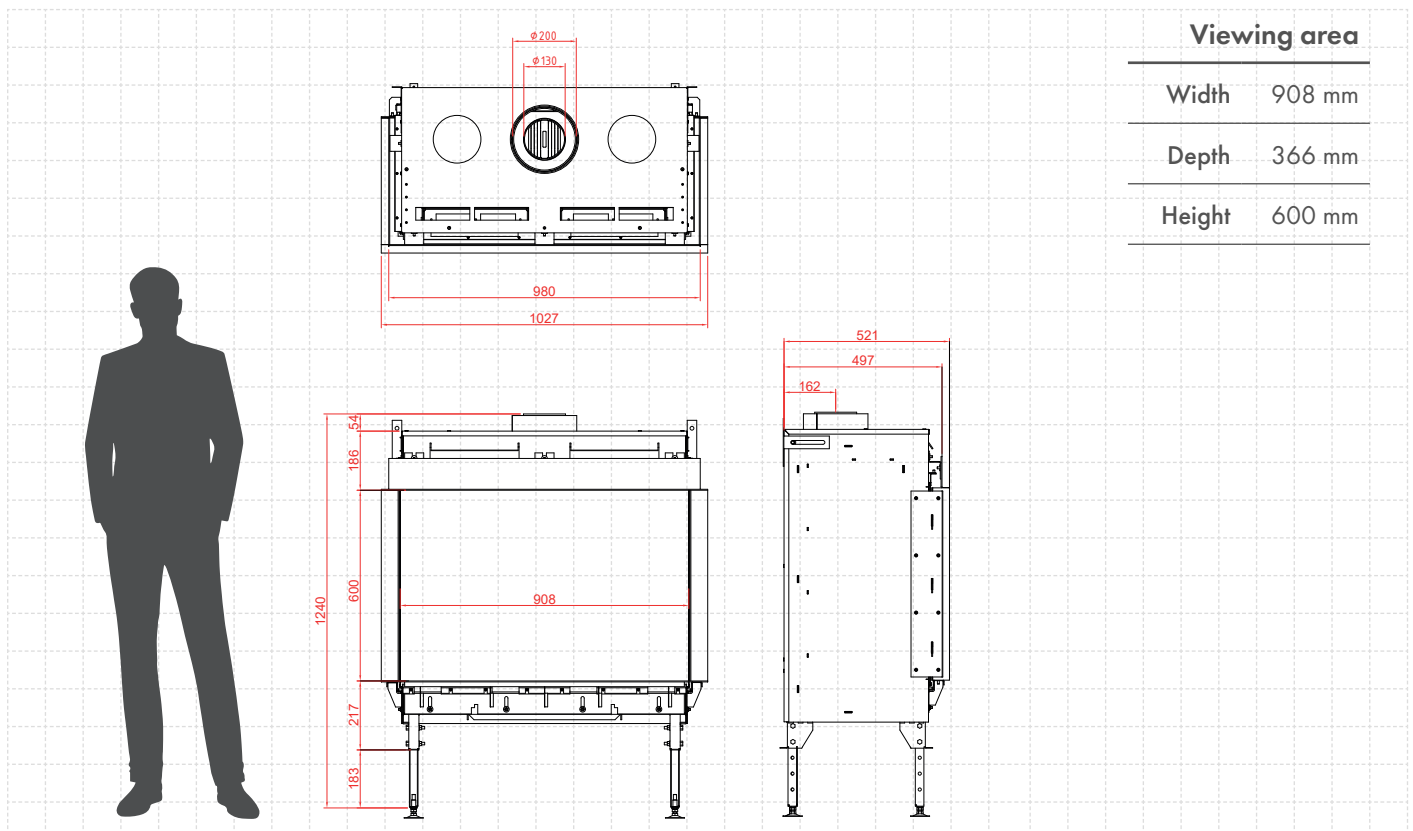

All product specifications and data are subject to change without notice and are believed to be accurate as of the date hereof. Planika Sp. z o.o., its affiliates, agents, and employees, and all persons acting on its or their behalf (collectively, "Planika Sp. z o.o."), disclaim any and all liability for any errors, inaccuracies or incompleteness contained in any document or in any other disclosure relating to any product. To the maximum extent permitted by applicable law, Planika Sp. z o.o. disclaims any and all liability arising out of the application or use of any product. This document does not expand or otherwise modify Planika Sp. z o.o.'s terms and conditions of purchase, including but not limited to the warranty expressed therein. No license, express or implied, by estoppel or otherwise, to any intellectual property rights is granted by this document or by any conduct of Planika Sp. z o.o.. Customers using or selling Planika Sp. z o.o.'s products not expressly indicated for use in such applications do so entirely at their own risk and agree to fully indemnify Planika Sp. z o.o. for any damages arising or resulting from such use or sale. The images are indicative only.